

Sliding Patio Doors



9 South Wardbark Place, Wardbark South, Cumbernauld, G67 3HX

t: 01236 780022

f: 01236 780021

email@adwlimited.co.uk

Our patio doors are manufactured on a lift and slide basis, using Siegenia-Aubi hardware. When the door is locked, it is lowered on to two bolts, which are attached to the stile of the frame. To open the door, the handle has to be turned 180° (fig. 1), which raises the door off its gasket and on to its wheels on the bottom track. Once the door is opened it can be lowered off its wheels and back on to the track at any position by moving the handle to the downward position (fig 2). The door can also be left on a night lock, where the doors are locked but a small gap is left for ventilation.



Our patio doors can be made from either softwood or hardwood. The cills for our patios are made from hardwood, regardless of the doors been made of softwood. The cills are also fitted with an aluminium tread to protect the wood.

We can manufacture patio doors up to 6 metres overall , with the door leafs up to 3 metres. We can manufacture our patio doors to a number of designs, which are drawn on the next page. We use Pilkington's safety glass in all our doors, however they can be made to your specification i.e. panels, astragals, mullions and transoms.

As a security feature, our Patio doors cannot be lifted off its rails due to two reasons

- 1) They slide internally, preventing anything from getting underneath the doors.
- 2) The locking bolts sit in a small hole in the door leaf which stops the door being lifted anymore than the length of the hole.

Patio Doors

Handle in the locked position

Handle in the open position

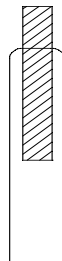

Fig 2

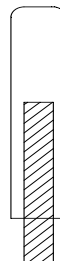
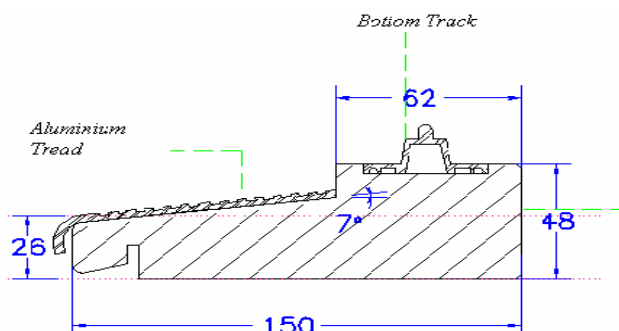

Fig. 1



ADW HIGH PERFORMANCE SLIDING DOORSETS



The Finest Quality Timber

We only use timber from sustainable forests to manufacture our products. European and Russian redwood, carefully selected by ourselves to ensure we reach the highest standard of quality and in accordance with BS1186 Part 1 1986, is mainly used to produce our products.

Where specified our doors systems can also be manufactured using the finest Hardwood with choices varying from Brazilian Cedar to Oak.

Lamination

Timber is laminated before it reaches the machinery, this allows the most suitable parts to be used and reduces warping of the wood to achieve the best performance and look.

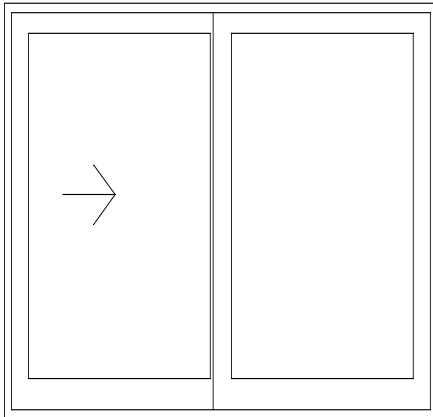

One door Leaf Sliding, One Fixed

Factory Pre-Finishing

Our products are supplied pre-finished. Our standard finish consists of a two-coat micro-porous water based paint. However factory pre-finishing is also available in a stain. The finish is applied to the timber using a spray method, which provides excellent coverage and allows us to effectively cover all areas of the product. Because of the care we take in pre-finishing our product maintenance intervals can be reduced.

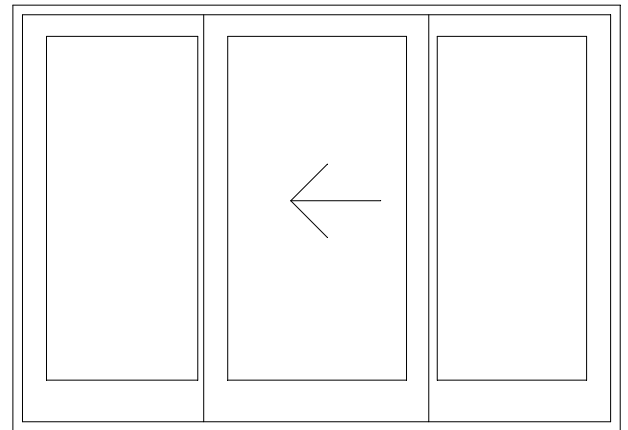

One door Leaf Sliding, Two Fixed

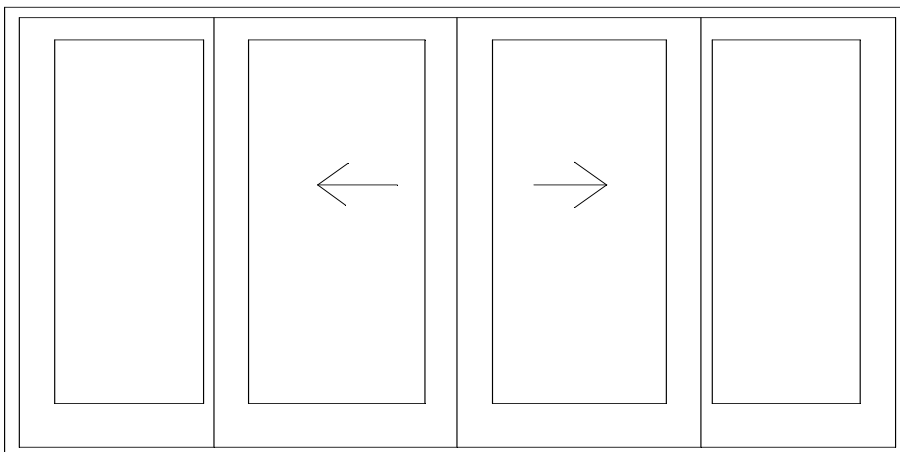

Two door Leafs Sliding, Two Fixed

Glass

As standard our windows are fitted with 24mm thick, sealed double glazing units. These compose of 2x4mm Toughened glass and a 16mm cavity. The inner pane has a low 'E' coating and complies with Part L of the Building Regulations. Active glass and other variations are available on request

Ironmongery

The doors are produced using Siegenia- Aubi Sliding Hardware, this ironmongery allows easy Operation of the Sliding door leaves by raising the door before sliding. The sliding Rolling wheels used is of steel construction for long term strength.

The handles are manufactured in a durable SAA finish, and a Ventilator is available fitted to the fixed doors if required.

The main locking mechanism consists of a 2-point locking system and a Euro Cylinder which can be locked from inside or out and provide optimum security.

TECHNICAL DETAILS

Head Section 149

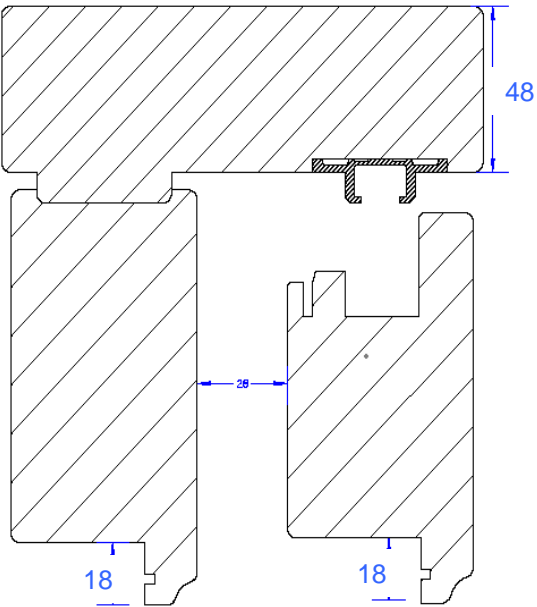

Sliding Patio Frame Head at Sliding Side

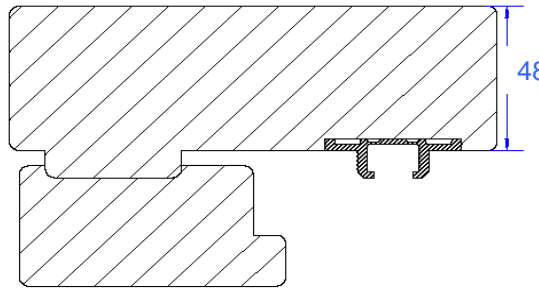

Fixed Leaf Jamb Stile 149

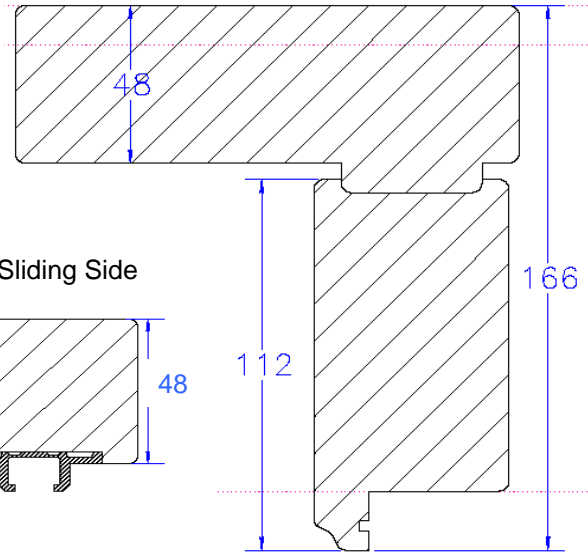

Sill detail at Sliding side

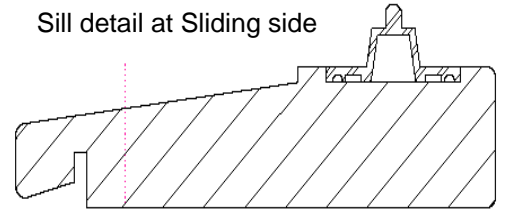

Passing Stiles

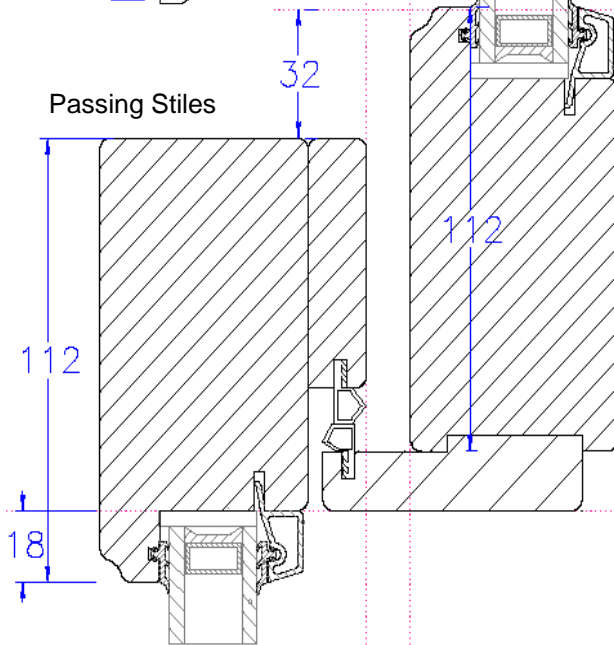

Bottom Stiles & Frame

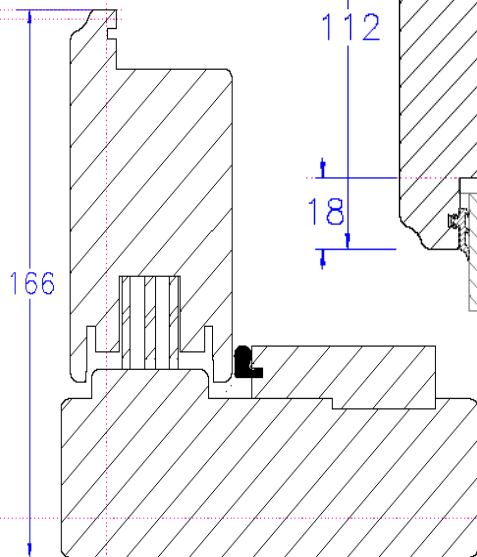
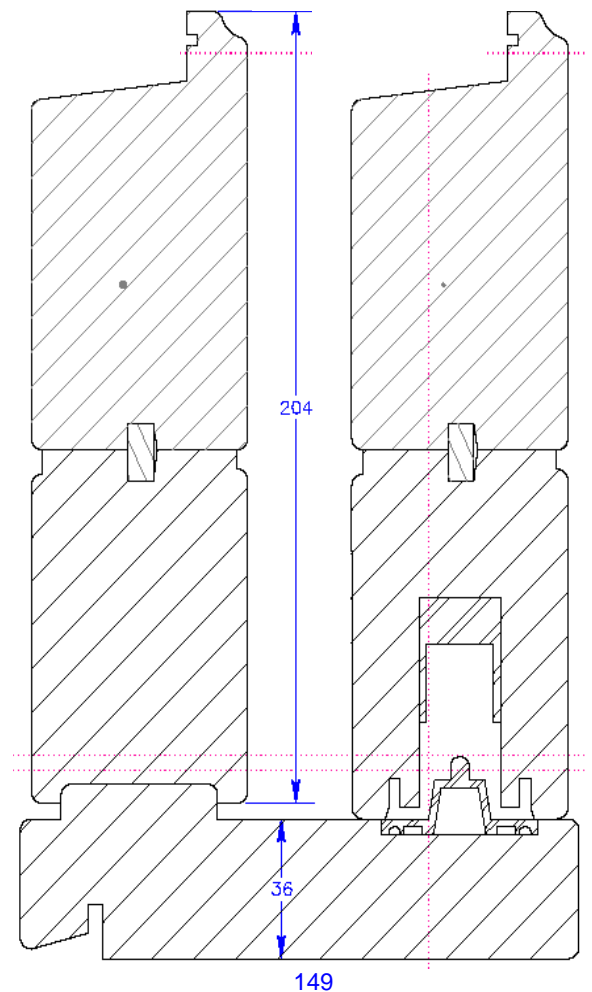

Sliding Leaf Jamb Stile

Drawings are not to scale

ADW

Architectural
Doors &
Windows
Limited

9 South Wardpark Place,
Cumbernauld, G67 3HX
Tel : 01236 780022
Fax : 01236 780021
Email @adwlimited.co.uk